

**FTXJ20-35MW**  
**FTXJ20-35MS**

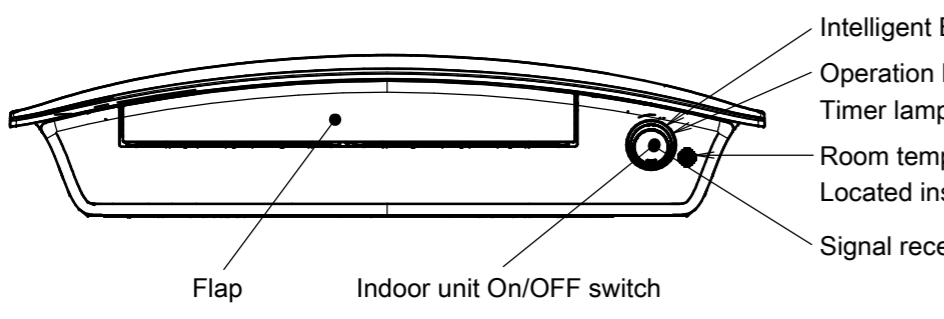

**Bottom view**

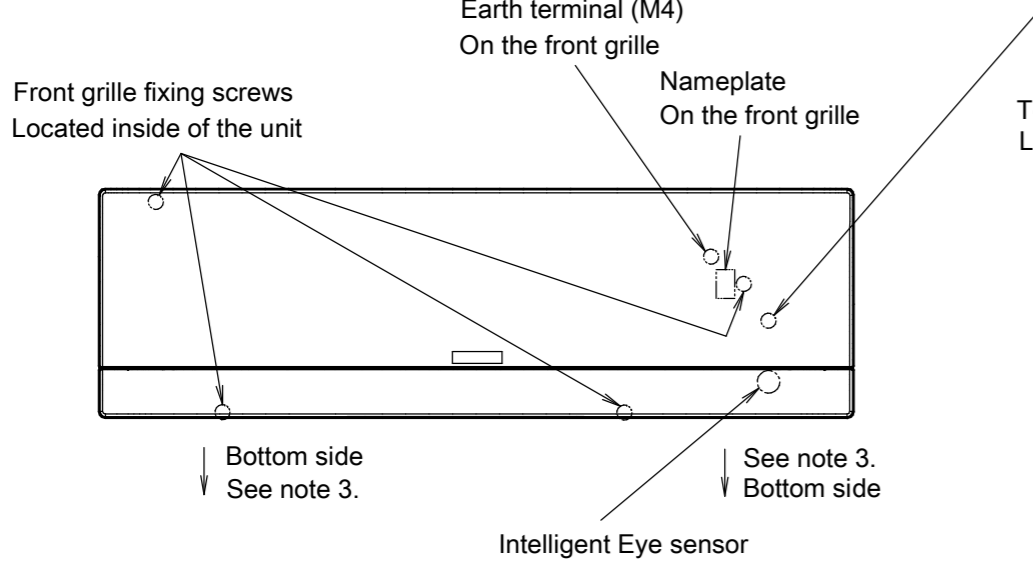
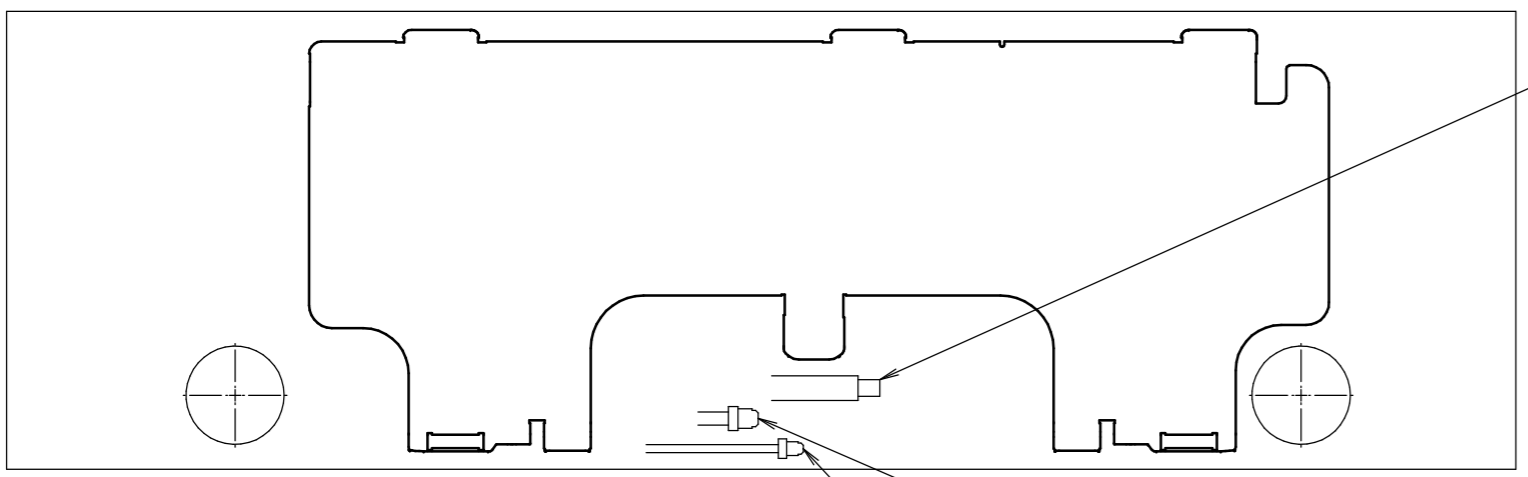

**Standard location of holes in the wall**

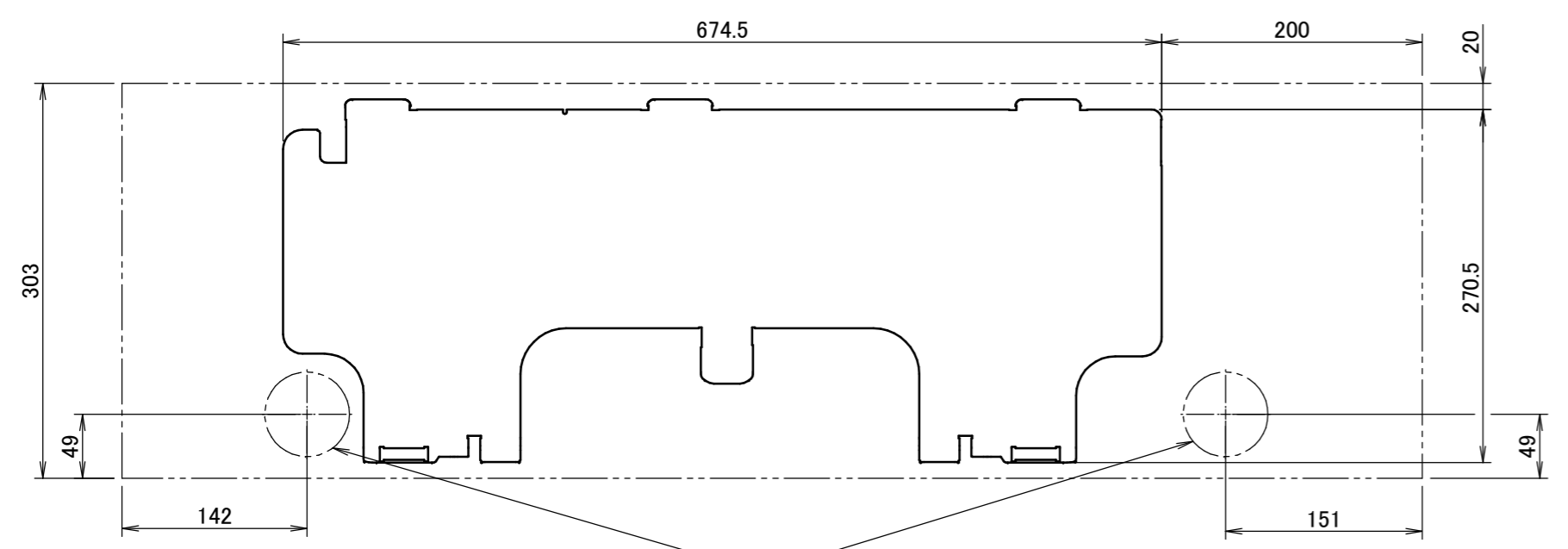

- Notes
1. The  $(\rightarrow)$  mark shows the piping direction.
  2. In this case, the optional grille is required.
  3. In this case, cut the grille according to the paper pattern.

**Wireless remote control**  
(ARC466A9)

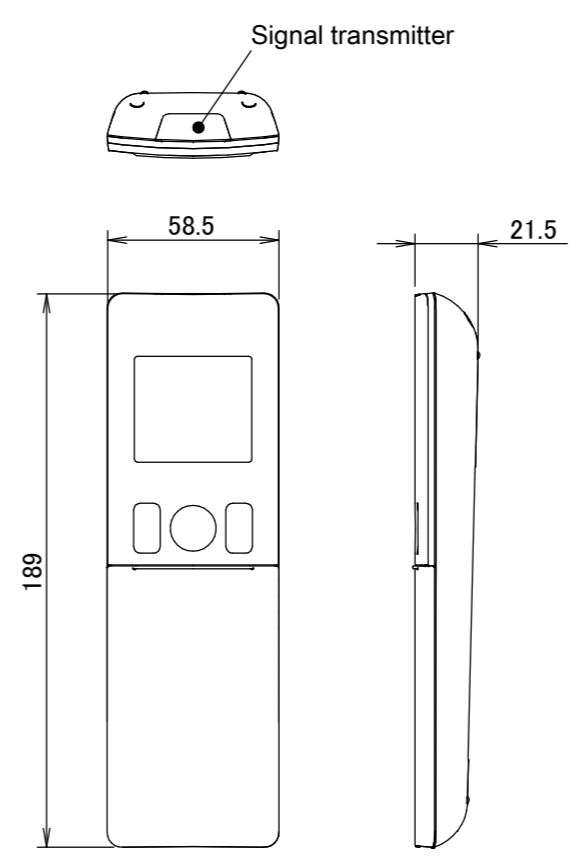

**Blade angle**

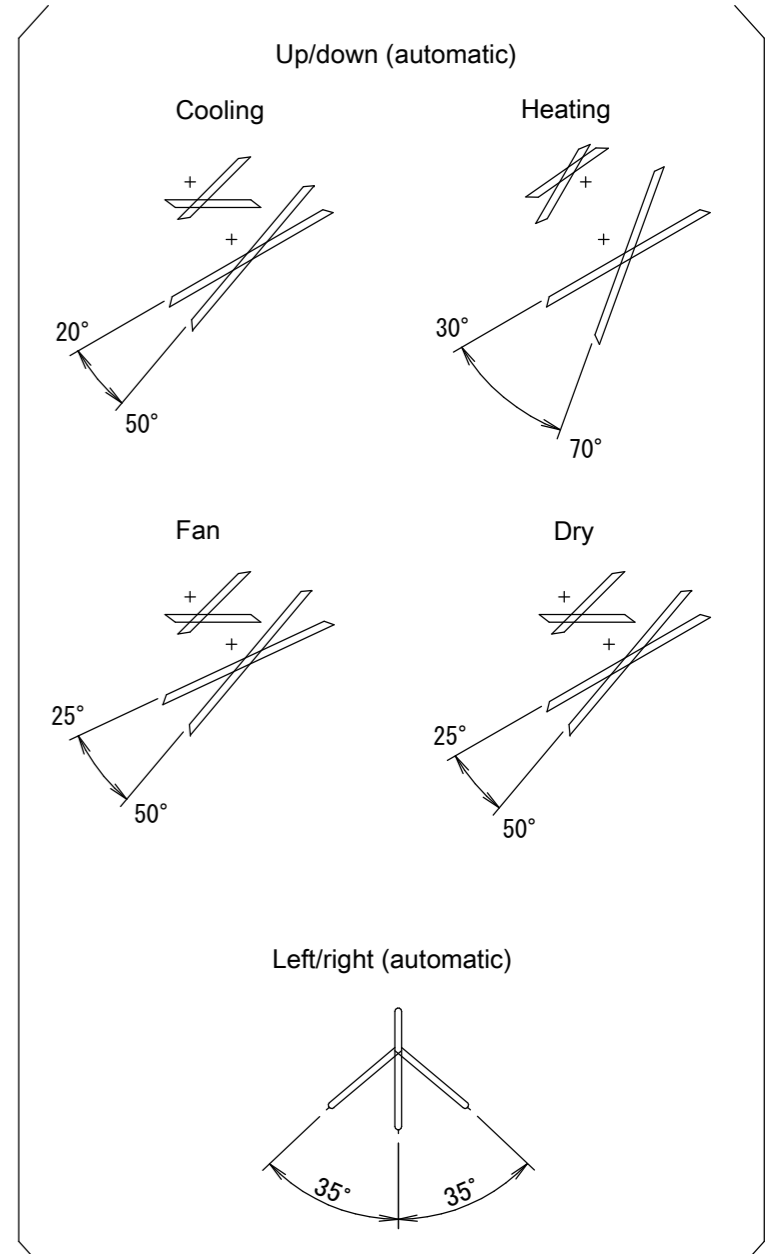

**Required space for service and ventilation**

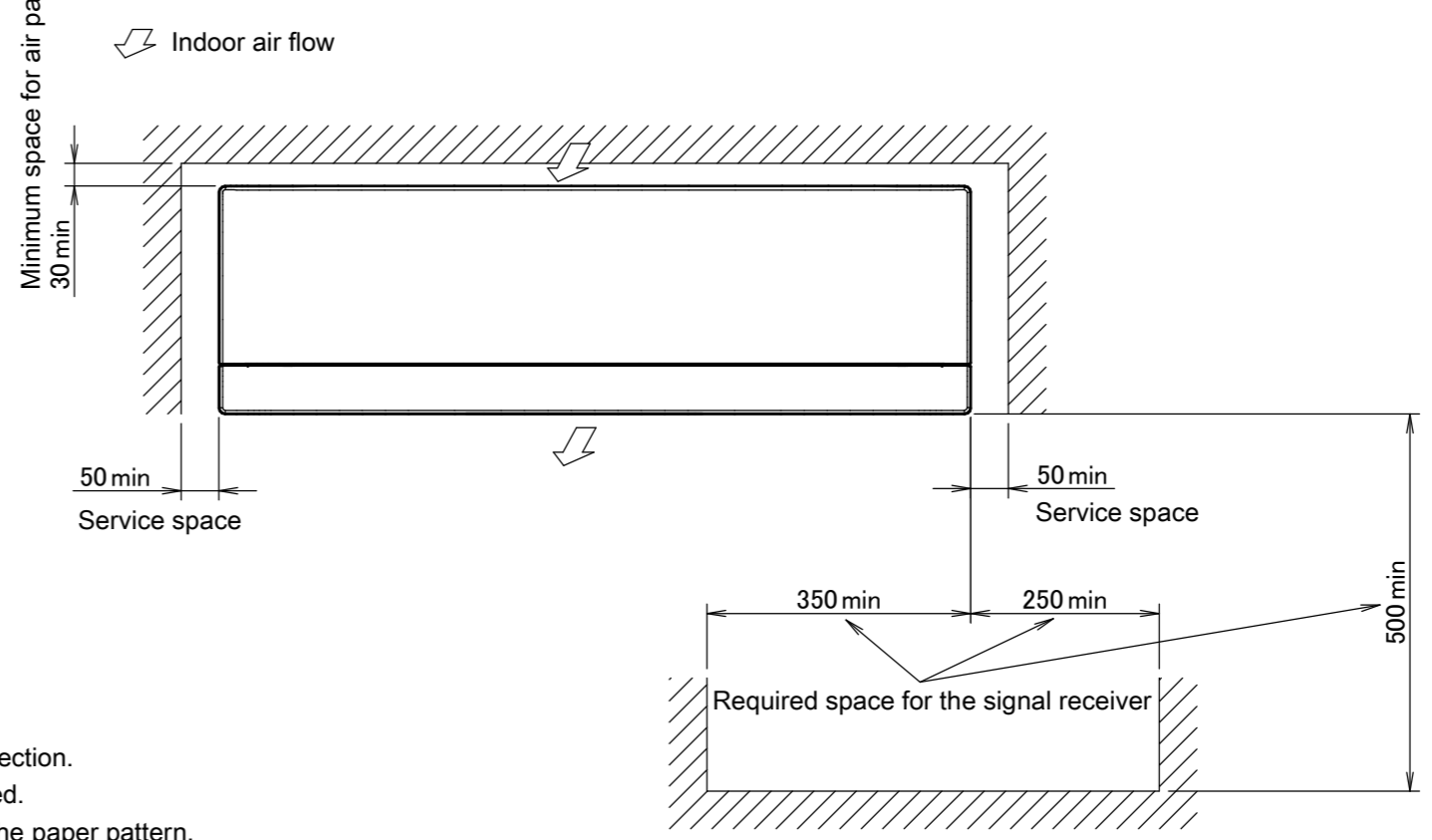

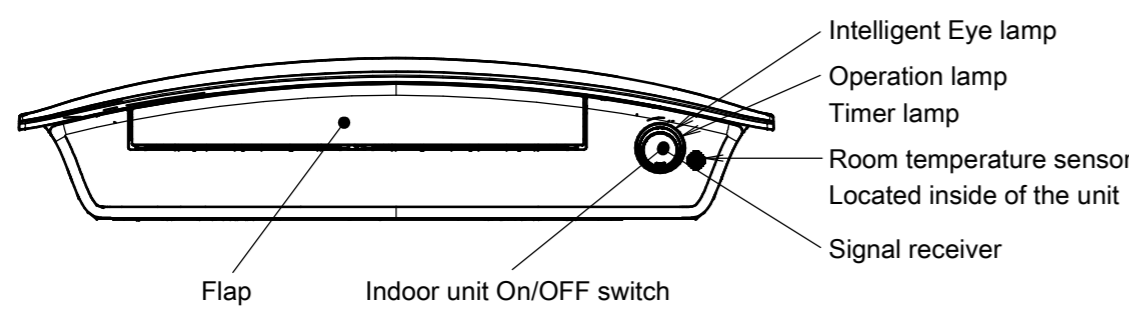
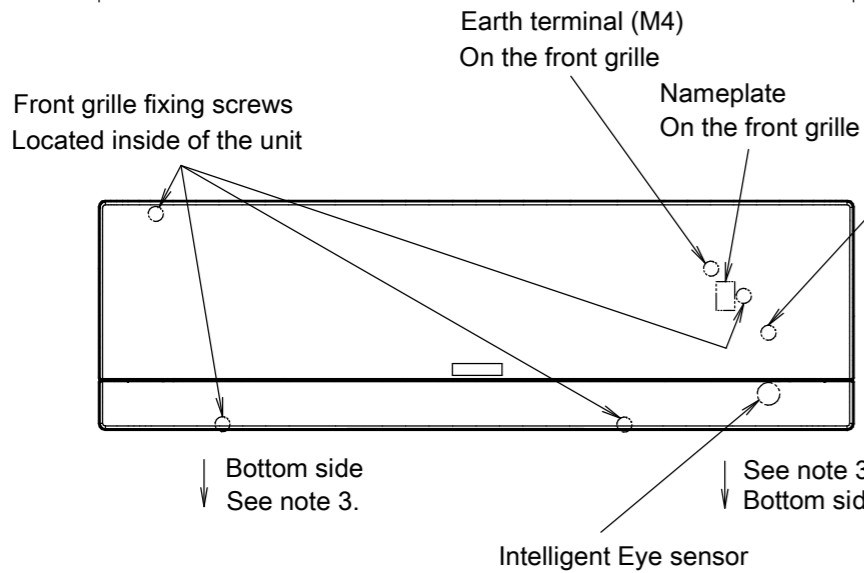
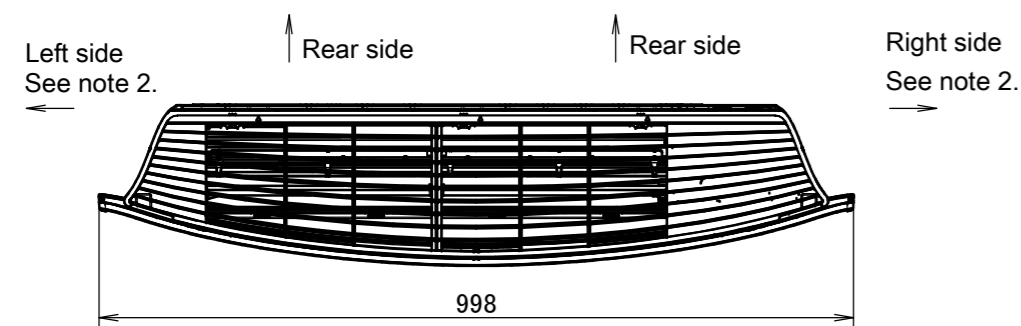

Bottom view

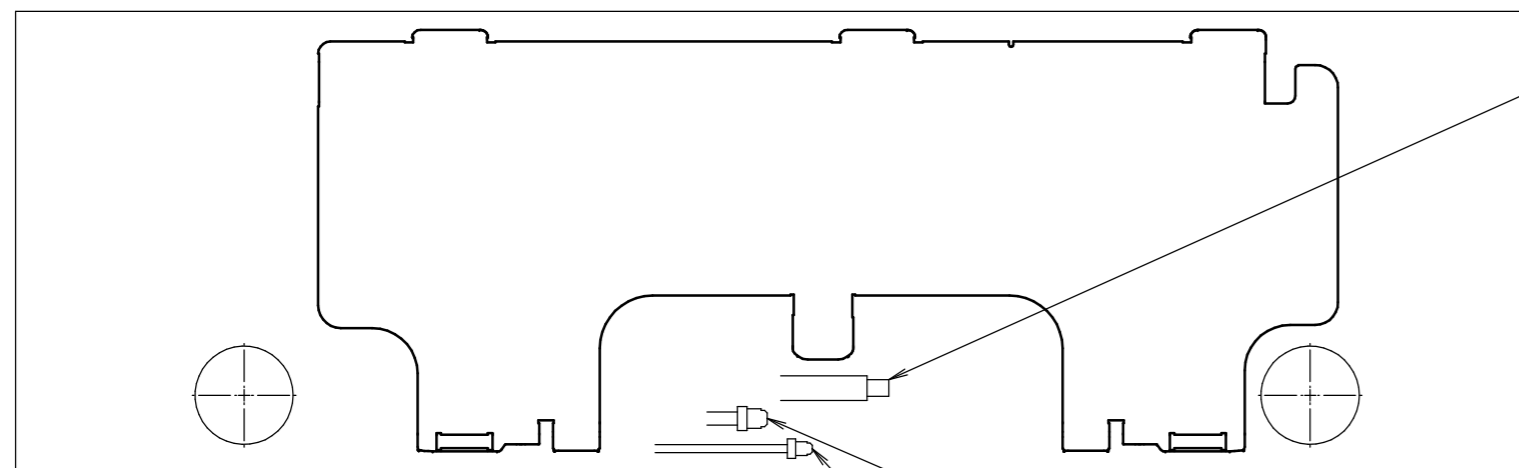

Standard location of holes in the wall

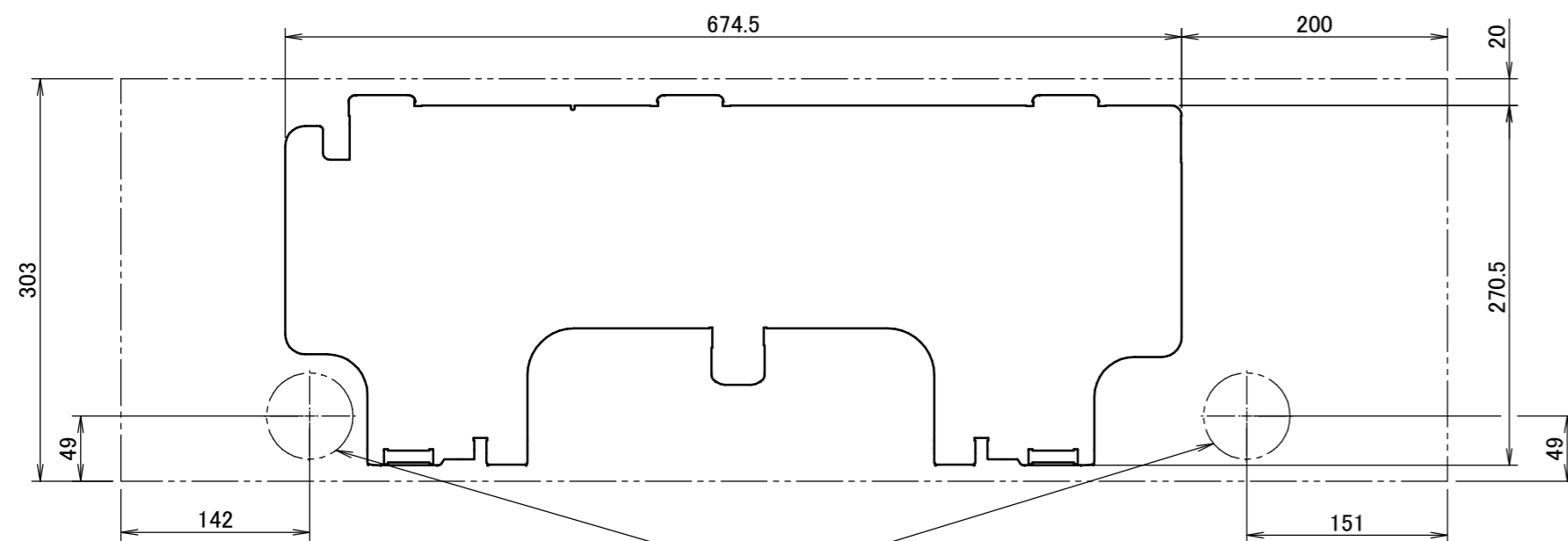

- Notes
1. The  $(\rightarrow)$  mark shows the piping direction.
  2. In this case, the optional grille is required.
  3. In this case, cut the grille according to the paper pattern.

Wireless remote control

(ARC466A9)

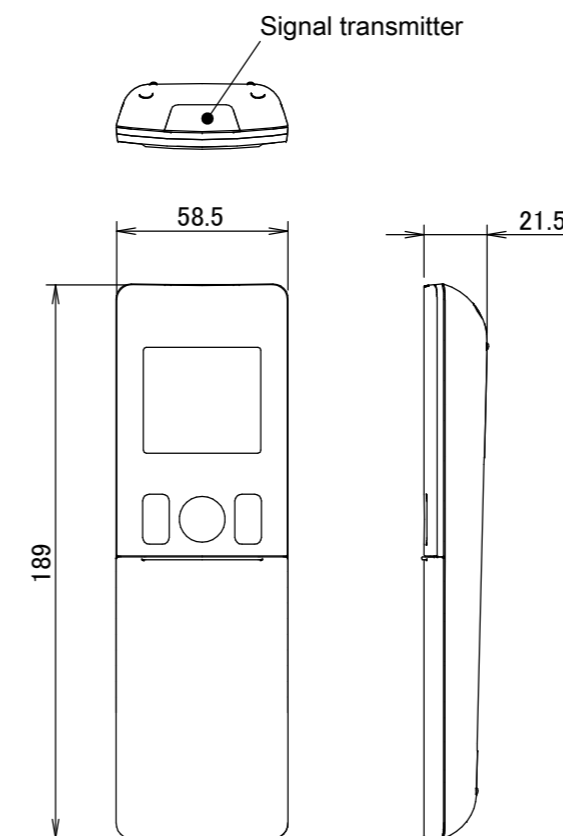

Blade angle

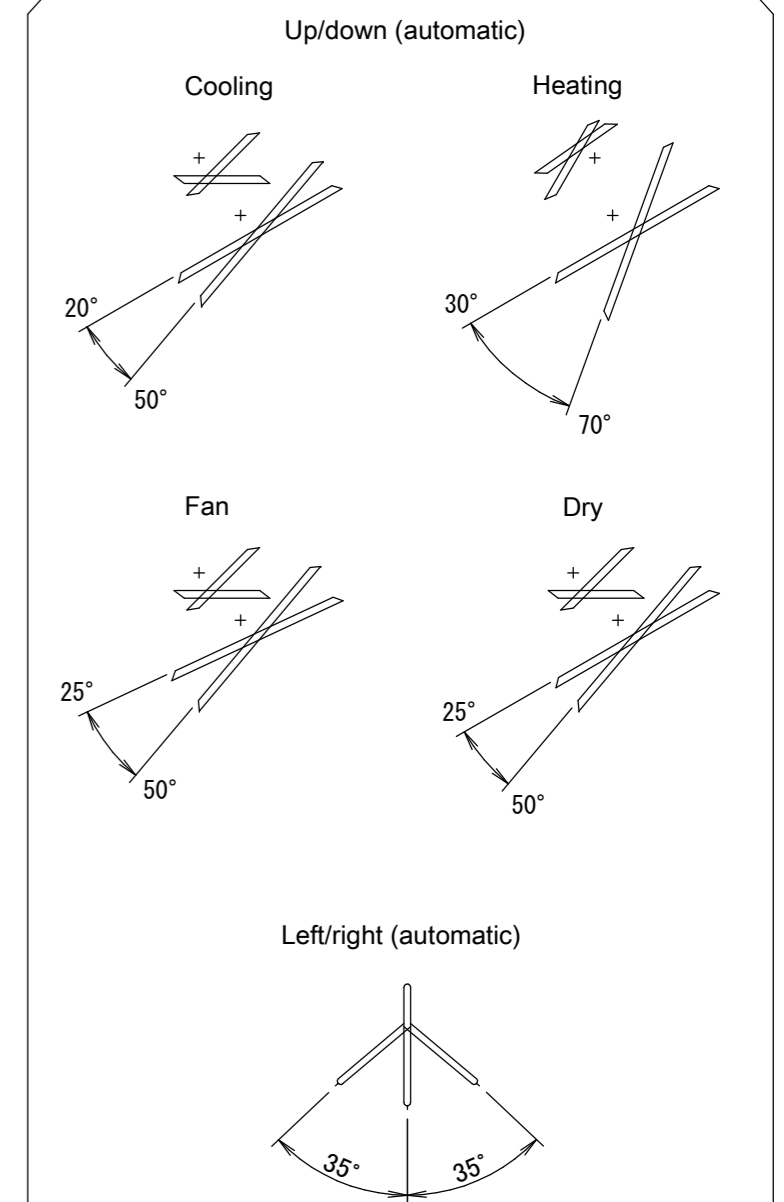

Required space for service and ventilation

